

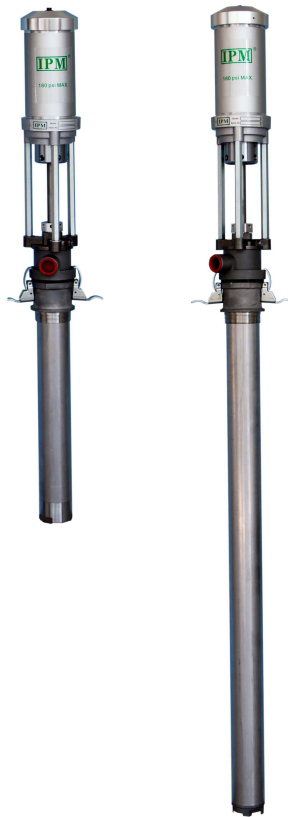

820307, 820308

OP SERIES

**2:1 RATIO TRANSFER PUMP
OPERATIONS MANUAL**



IPM, INC.

Manufactured by: International Pump Manufacturing, Inc.

OP300S / OP350

2:1 RATIO TRANSFER PUMPS

OPERATIONS MANUAL and PARTS IDENTIFICATION DRAWINGS

This manual contains IMPORTANT WARNINGS and INSTRUCTIONS. Read and retain for future reference.

INTERNATIONAL PUMP MANUFACTURING, INC.
3107 142nd Avenue E Suite 106,
Sumner, WA 98390
U.S.A.
TEL: (253) 863 2222
FAX: (253) 863 2223
Website : www.ipmpumps.com

For Technical Service Call Your Local Distributor

Copyright 2014 by: International Pump Mfg, Inc.

WARNING: The equipment described herein must only be operated or serviced by properly trained individuals thoroughly familiar with the operating instructions, mechanics and limitations of the equipment.

Notice: All statements, information and data given herein are believed to be accurate and reliable but are presented without guarantee, warranty or responsibility of any kind expressed or implied. Statements or suggestions concerning possible use of IPM equipment are made without representation or warranty that any such use is free of patent infringement, and are not recommendations to infringe any patent. The user should not assume that all safety measures are indicated or that other measures may not be required.

TABLE OF CONTENTS

1.0 SAFETY WARNINGS	4
2.0 INSTALLATION	8
3.0 DISASSEMBLY.....	9
4.0 PARTS IDENTIFICATION.....	12
5.0 TROUBLESHOOTING	19
6.0 TECHNICAL SPECIFICATIONS	20
7.0 PERFORMANCE.....	21
8.0 WARRANTY AND DISCLAIMER	23

1.0 SAFETY WARNINGS

Please read and observe all warnings contained in this operations manual before making any attempt to operate the equipment.

Warning

To reduce the risk of static sparking or splashing fluid in the eyes or on the skin, follow the **Pressure Relief Procedure** before flushing.

For your safety, read the **Fire or Explosion Hazard** before flushing and follow all the listed recommendations.

Misuse of equipment

Misuse of equipment can cause serious bodily injury. Use the equipment only for its intended purpose and do not attempt to modify it in any way. Care should be taken to prevent over pressurization of the pump, hose lines and accessories connected to it. Use only IPM designated parts for re-building or repairing this equipment. Use the pump only with compatible fluids. Improper use of this equipment could result in fluid being sprayed on the skin or in the eyes of user, serious bodily injury, property damage, fire or explosion.

Daily maintenance inspection should be made on pumps and equipment and all worn or damaged parts should be re-placed immediately. Do not use pumps, components or hose lines as leverage to move equipment to avoid damage and injury. Do not alter this equipment as doing so could cause it to function incorrectly and/or cause serious injury. Altering this equipment in any way will also void any and all warranty guarantees from the manufacturer.

Material & fluid compatibility

Always ensure the chemical compatibility of the fluids and solvents used in the fluid section of these pumps, hoses other components. Check the chemical manufacturer's data sheets and specification charts before using fluids or solvents in this pump to ensure compatibility with pumps, inner hose lining and outer hose covering.

Pressurized hoses

Because the hoses are pressurized they can present a danger should the fluid escape due to damage, worn parts or general miss-use. Escaping fluid can splash or spray operator, causing serious bodily injury and/or damage to equipment and property. Ensure that the hoses do not leak or rupture due to wear, misuse or damage.

Before each use, ensure that the fluid couplings are tight and all clips/pins/plugs are secured. Inspect the entire length of hose for wear, cuts, abrasions, bulging cover and/or loose connections. These conditions may cause the hose to fail and result in splashing or spraying of chemicals on the skin or in the eyes of operator and cause serious injury and/or property damage.

Pressure specification

The maximum working pressure of this equipment for fluids and air is *180 psi (12.4 bars)*. Ensure all equipment and accessories used with this pump are rated to withstand the maximum working pressure of this pump. Never exceed the maximum working pressure of the pump, hose lines or any other components attached to the pump itself.

Pressure relief procedure

In order to avoid the risk of serious injury to operators from splashing/spraying chemicals, the following safety procedures should be used. This procedure should be used when shutting down the pump, performing general maintenance, repairing a pump or other components of the system, replacing components or when pumping operation is ceased.

1. Close the air valve to the pump.
2. Use the air bleed down valve to relieve the air pressure in the system.
3. Relieve the fluid pressure by holding a grounded metal pail in contact with the metal part of the fluid dispense valve and slowly opening the valve.
4. With a container ready to catch the fluid, open the drain valve.
5. It is a good practice to leave the drain valve open until it is time to dispense fluid again.

If you are unsure that the fluid pressure has been relieved due to a blockage in a component or a hose, carefully relieve the pressure by carefully loosening the hose end coupling to allow the fluid pressure to escape slowly. After the pressure has been relieved, the fitting can then be removed and any blockages removed. If the pump is to remain idle for only a short period of time, it is not necessary to empty the wet cup.

Flushing

1. The pump is tested with lightweight oil, which is left in to protect the pump parts. If the fluid you are pumping may become contaminated by oil, flush oil from pump with a compatible solvent before use. Follow the flushing instruction below.
2. When pumping fluids that set up or solidify, flush the system with a compatible solvent as often as necessary to remove build-up of solidified chemicals in the pump or hoses.
3. If the pump is being used to supply a circulating system, allow the solvent to circulate through the entire system for at least 30 minutes every 48 hours or more often if necessary to prevent settling and solidification of chemicals.
4. Once a pump is committed to a particular chemical, it is good practice to identify which chemical a particular pump is designated for to eliminate the possibility of mix up and contamination.

Shutdown

For overnight shutdown, follow the *Pressure Relief Procedure*. Always stop the pump at bottom of the stroke to prevent the fluid from drying on the exposed displacement rod and damaging the throat packing.

Hazards from fire or explosion

Hazards exist where sparks can ignite vapors or fumes from combustible chemicals or other hazardous conditions exist such as explosive dust, etc. These sparks can be created from plugging in or unplugging an electrical supply cord or from the static electricity generated by the flow of fluid through the pump and hose.

Every part of the equipment must be properly grounded to prevent static electricity from generating a spark and causing the pump or system to become hazardous. These sparks can cause a fire, explosion, property and equipment damage and serious bodily injury. Ensure that the pump and all components and accessories are properly grounded and that electrical supply cords are not plugged in or unplugged when these hazards exist.

Should any evidence of sparks or static electricity exist, discontinue pump operation immediately. Investigate the source of the static electricity and correct the grounding problem. Do not use the system until the grounding problem is repaired.

Grounding procedure

Grounding of the pump and all components are necessary to minimize the possibility of sparks due to static electricity. Grounding must be in compliance with local electrical codes. Check with the local authorities for requirements in your area and with the type of equipment being used.

Ensure that all the following equipment are grounded correctly:

1. Pump : Loosen the lock screw to allow insertion of one end of a minimum sized 12 gauge wire into the bore hole of the grounding lug. Insert wire and tighten the lock screw securely. Secure the other end of the ground wire to a true earth ground. See FIG. A

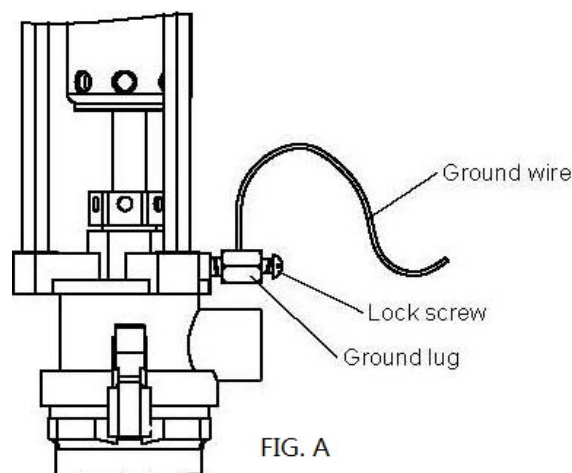

- | | |
|---|--|
| 2. Air compressor : | Follow the grounding procedures as recommended by the compressor manufacturer. |
| 3. Air hoses : | Always use grounded air hoses. |
| 4. Fluid container used to supply the system : | Grounding must be done according to local electrical codes. |
| 5. Fluid Hoses : | Always use grounded fluid hoses. |
| 6. Dispensing Valve : | The valve must be metal to conduct through the fluid hose to the pump which must be properly grounded. |
| 7. Dispensing Point : | Grounding must be done according to local electrical codes. |
| 8. Solvent Containers : | Grounding must be done according to local electrical codes. use only metal conductive pails that are properly grounded. |
| 9. Grounding while dispensing, cleaning or relieving pressure : | Maintain conductivity by firmly securing the metal part of the dispensing valve to the side of a grounded metal container. |

It is very important that the hoses used for both air and fluid dispensing be a grounding type and that ground continuity is maintained at all times during operation. Regular checks of the hose ground resistance (with a resistance meter using a suitable range) and a comparison to the manufacturer's specification will ensure that the ground is within specifications. If it is not within specified limits it should be replaced immediately.

Solvent cleaning

While cleaning the system with solvent, secure the metal part of the dispensing valve in contact with a grounded metal pail to minimize the possibility of splashing/spraying of chemicals on the skin, in the eyes and around static sparks. Use low fluid pressure for additional safety.

Hazards from moving parts

Use the *Pressure Relief Procedure* to prevent the pump from starting unintentionally or unexpectedly. Be aware of moving parts that present a pinching hazard to fingers or other body parts. Stay clear of these moving parts at all times when starting or operating the pump.

Safety standards

Safety standards have been established by the United States Government under the Occupational Safety and Health Act. These standards should be consulted as they apply to the hazards and type of equipment being used.

2.0 INSTALLATION

1. Use thread sealer on the male threads of the ball valve and quick disconnect plug. Install in the air inlet as shown.

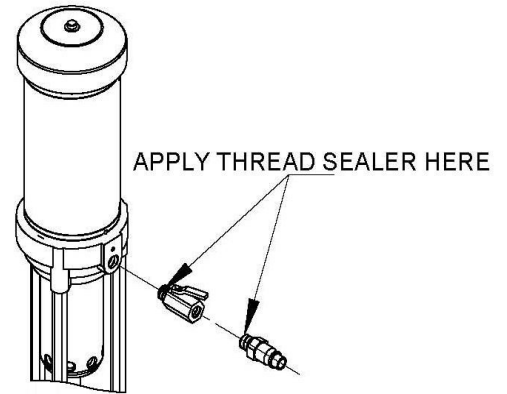

2. Screw the bung adaptor onto the mount bracket. Carefully slide the transfer pump through the adaptor and lock it in place with the bung adaptor latch hooks.

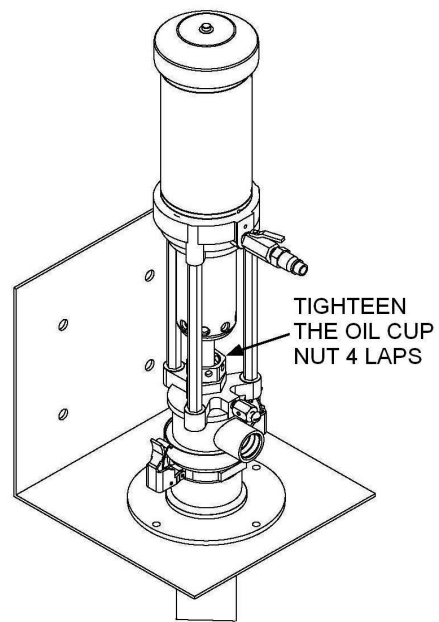

3. Attach air line onto quick disconnect fitting to complete installation. It is recommended to use a minimum 3/8" hose for the pump air supply.

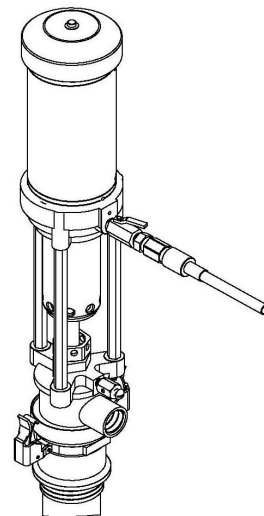

3.0 DISASSEMBLY

1. Disconnect all air and hydraulic pressures from pump for safety.
2. Place the pump in a vice being careful not to damage equipment. Pipe clamps will serve in the event you do not have a vice available.

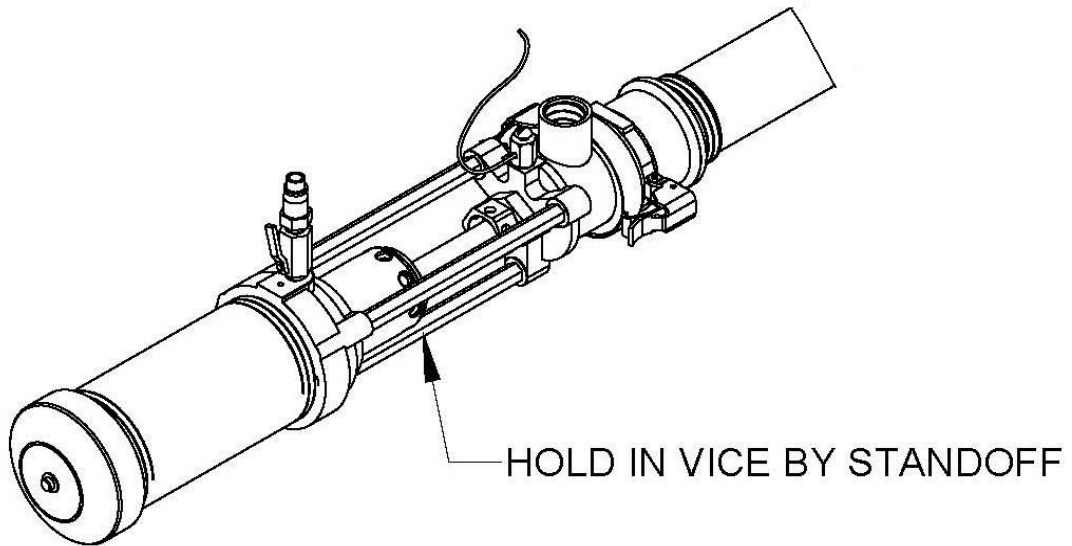

3. Open the ball valve to remove any trapped air in the air section.

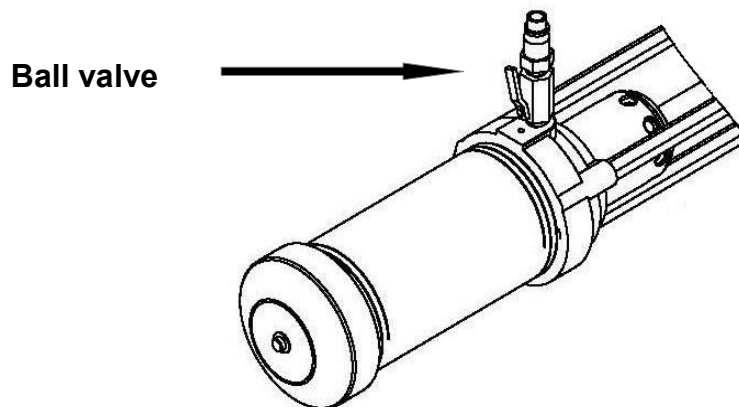

4. Place a strap wrench around the lower end of the air cylinder and carefully unthread.

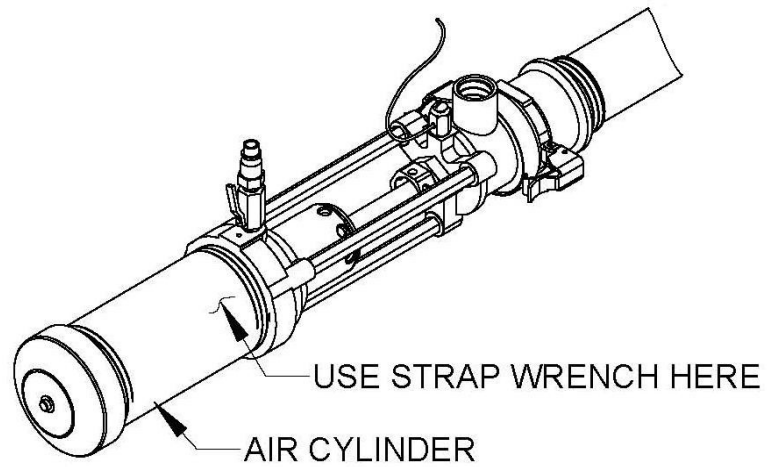

5. Use a 5/16" steel dowel pins to keep the piston rod plunger from rotating. Unthread the piston.

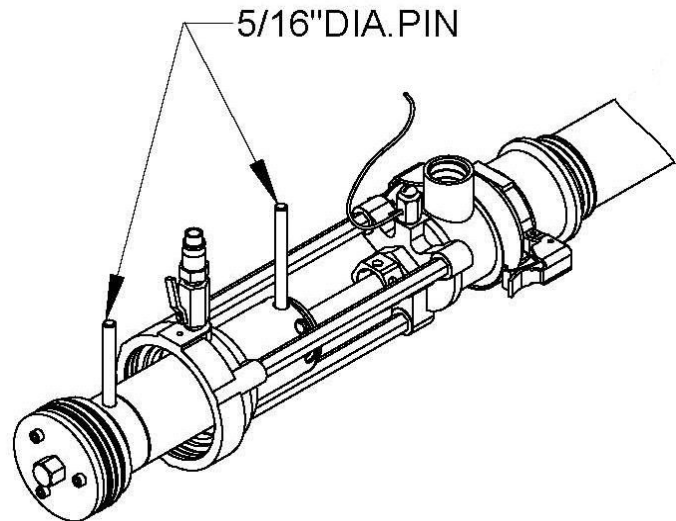

6. Remove the dowel pin from the plunger top. Air motor assembly can now be removed from the displacement plunger and main shaft.

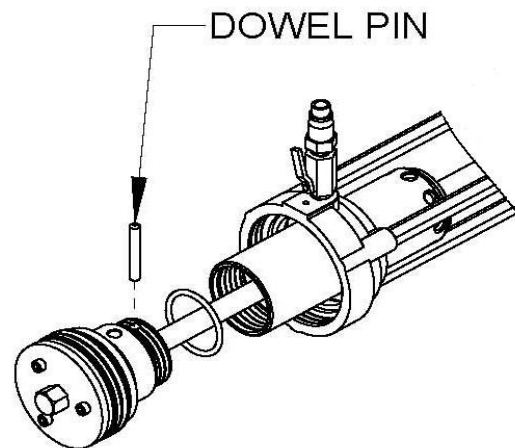

NOTE : Upper hex nut is a permanent part of upper air valve plate (#700003).

Do not use a wrench on hex nut during disassembly, assembly or maintenance of air motor assembly.

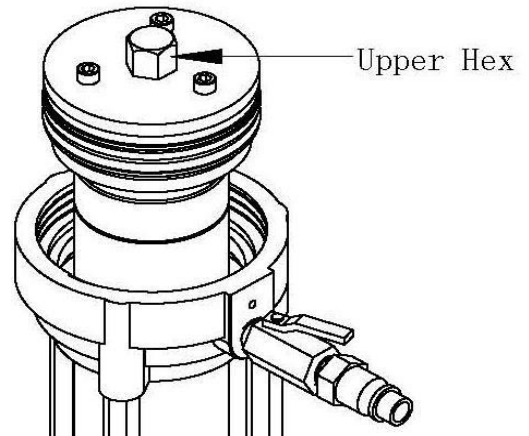

7. Remove the foot valve from the suction tube and push the main shaft out through the suction tube.

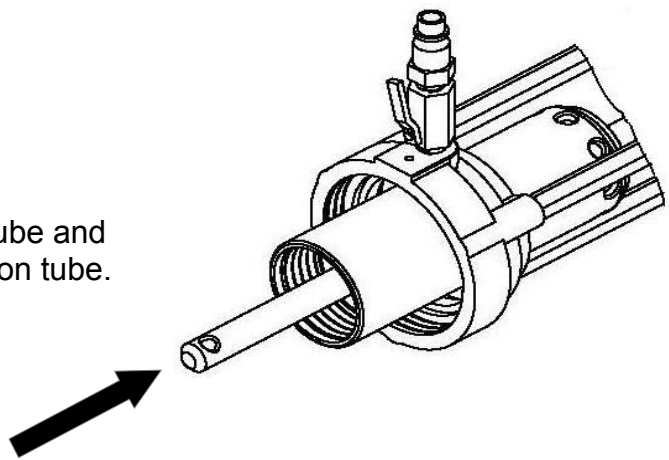

8. Remove the set screw and "U" cup retaining collar (501604) from the main shaft.

9. Inspect and replace the packings as required paying careful attention to the packing orientation.

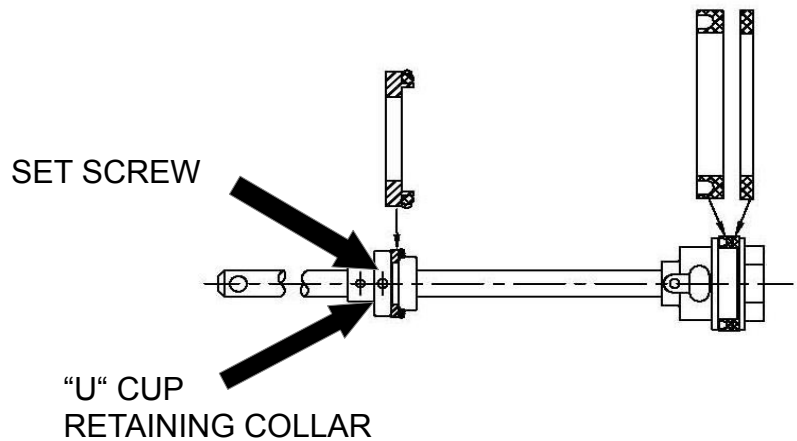

10. Lubricate, install, and assemble the parts in reverse order.

4.0 PARTS IDENTIFICATION

Air Piston Assembly (Part Number 700004)

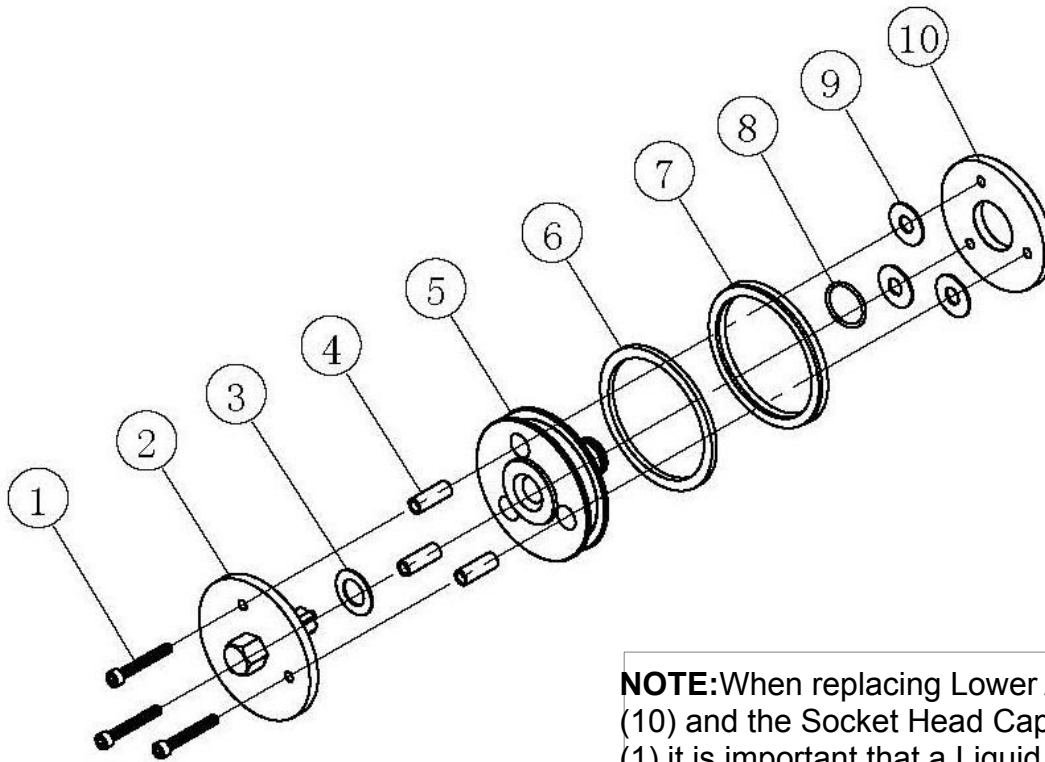

NOTE:When replacing Lower Air Valve (10) and the Socket Head Cap Screws (1),it is important that a Liquid Thread Sealing Compound be use to prevent the assembly from vibrating loose.

ITEM	PART NUMBER	DESCRIPTION	QUANTITY
1	500014	Socket Head Cap Screw	3
2	700003	Upper Air Valve Assembly	1
3 *	500015	Gasket Top	1
4	500012	Spacer	3
5	500011	Air Piston	1
6 *	500017	Wear Ring	1
7 *	500018	U-Cup	1
8 *	500019	O-Ring	1
9 *	500016	Gasket Bottom	3
10	500013	Lower Air Valve	1

* Included in the Repair Kit (part number 601018).

Air Motor Section (Model OP300S / OP350)

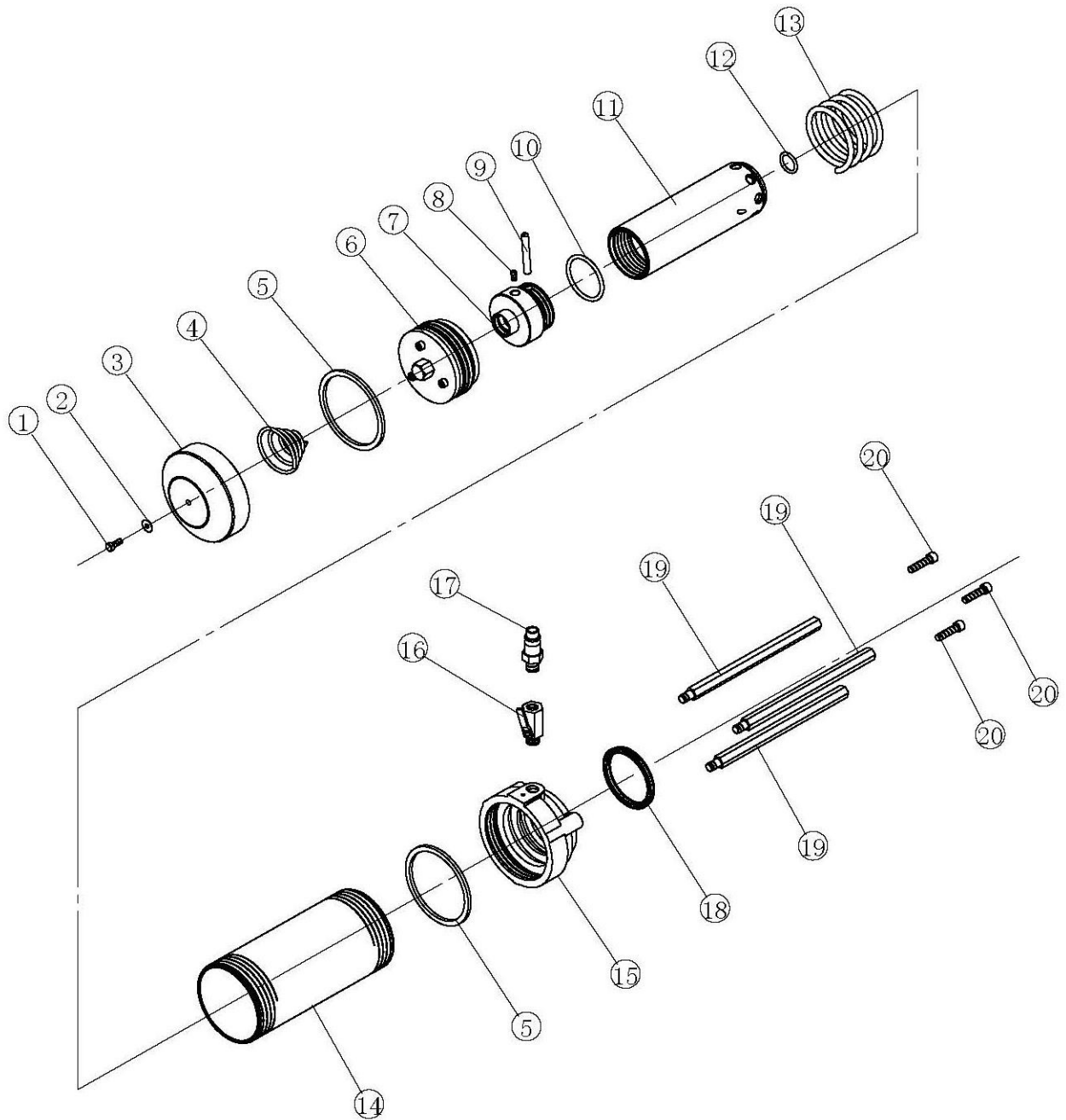

NOTE:When replacing Socket Set Screw (8) and the Plunger Top (7), it is important that a Liquid Thread Sealing Compound be used to prevent the assembly from vibrating loose.

Air Motor Section (Model OP300S / OP350)

ITEM	PART NUMBER	DESCRIPTION	QUANTITY
1	500001	Pressure Relief Screw	1
2	500002	Fiber Washer	1
3	700001	Air Cylinder Cap Assembly	1
4	500005	Tapered Spring	1
5 *	500006	O-Ring	2
6	700004	Air Motor Assembly	1
7	500020	Plunger Top	1
8	500021	Socket Set Screw	1
9	500022	Dowel Pin	1
10 *	500023	O-Ring	1
11	700113	Displacement Plunger Assembly	1
12	500056	O-Ring	1
13	500026	Spring	1
14	700002	Air Cylinder Assembly	1
15	500027	Air Cylinder Base	1
16	501804	Ball Valve	1
17	500029	Male Plug	1
18 *	500030	U-Cup	1
19	500032	Standoff	3
20	500040	Socket Head Cap Screw	3

* Included in the Repair Kit (part no. 601018).

Fluid Section (Model OP300S)

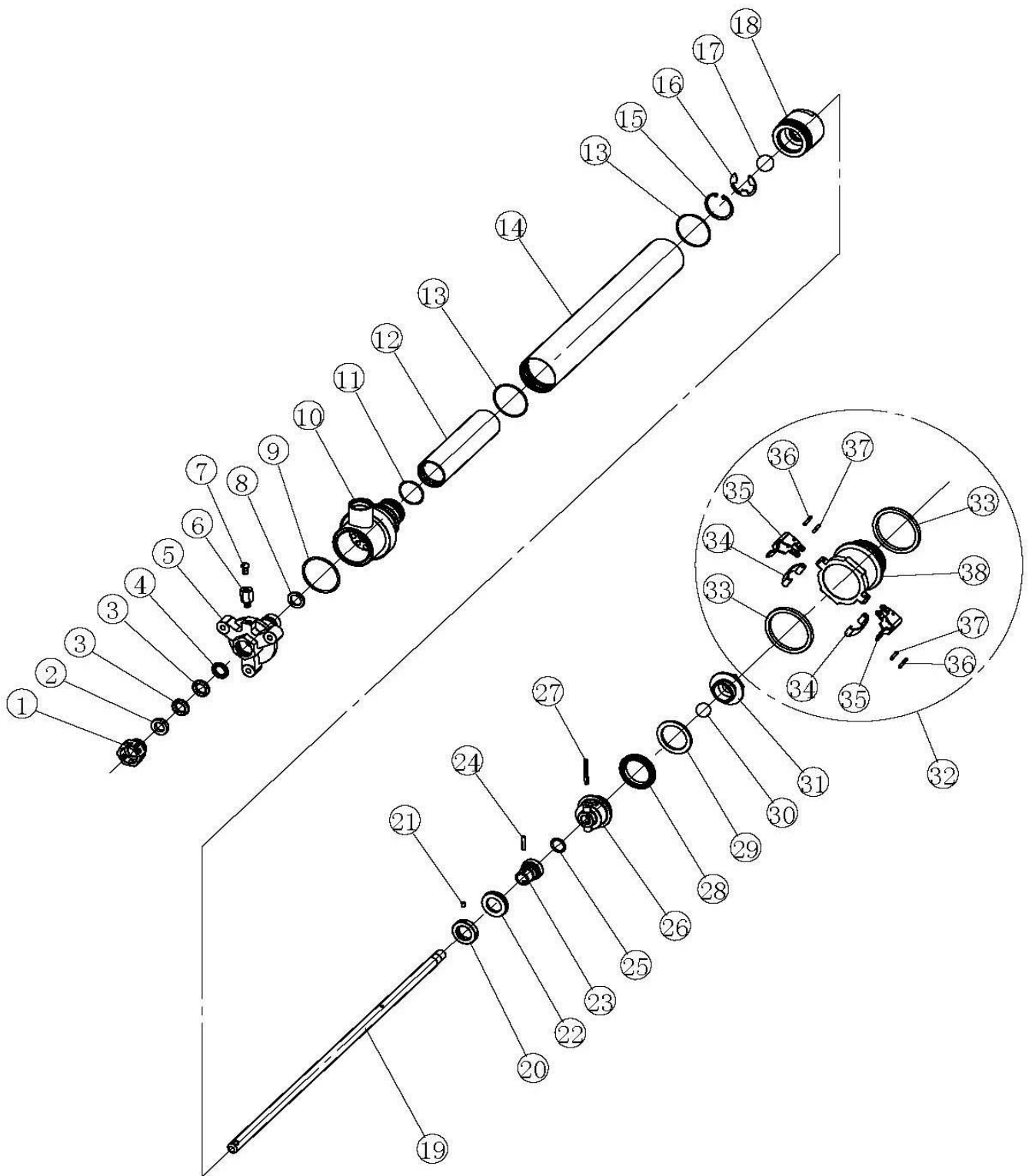

Fluid Section (Model OP300S)

ITEM	PART NUMBER	DESCRIPTION	QUANTITY
1	501641	Oil Cup Nut	1
2 *	500033	Seal Retainer	1
3 *	500034	V- Packing	2
4 *	500035	Seal Expander	1
5	500037	Air Cylinder Mtg Flange	1
6	500038	Grounding Lug	1
7	500039	Round Head Screw	1
8 *	500041	Gasket	1
9 *	500042	O-Ring	1
10	501638	Base	1
11 *	501632	O-Ring	1
12	501639	Pump Pressure Cylinder	1
13 *	500066	O-Ring	2
14	501642	Suction Tube	1
15	500193	Snap Ring	1
16	500192	E-Clip	1
17	500269	Ball	1
18	500087	Foot Valve Housing	1
19	501644	Main Shaft	1
20	501604	U-Cup Retaining Collar	1
21	500062	Soft Point Set Screw	1
22 *	501643	Piston Cup Packing	1
23	500059	Upper Matl Piston-Bottom	1
24	500055	Roll Pin	1
25 *	500056	O-Ring	1
26	500057	Material Piston Housing	1
27	500054	Roll Pin	1
28 *	500063	U-Cup	1
29 *	500064	Wear Ring	1
30	500068	Ball	1
31	500065	Piston Valve Housing	1
32	700008	Bung Adapter Assembly (include 33-38)	1
33 *	500053	Gasket	2
34	500050	Latch Spring	2
35	500049	Clamp Lever	2
36	500051	Roll Pin	2
37	500052	Roll Pin	2
38	500048	Bung Adapter	1

*Included in the Repair Kit (part no. 601045).

Fluid Section (Model OP350)

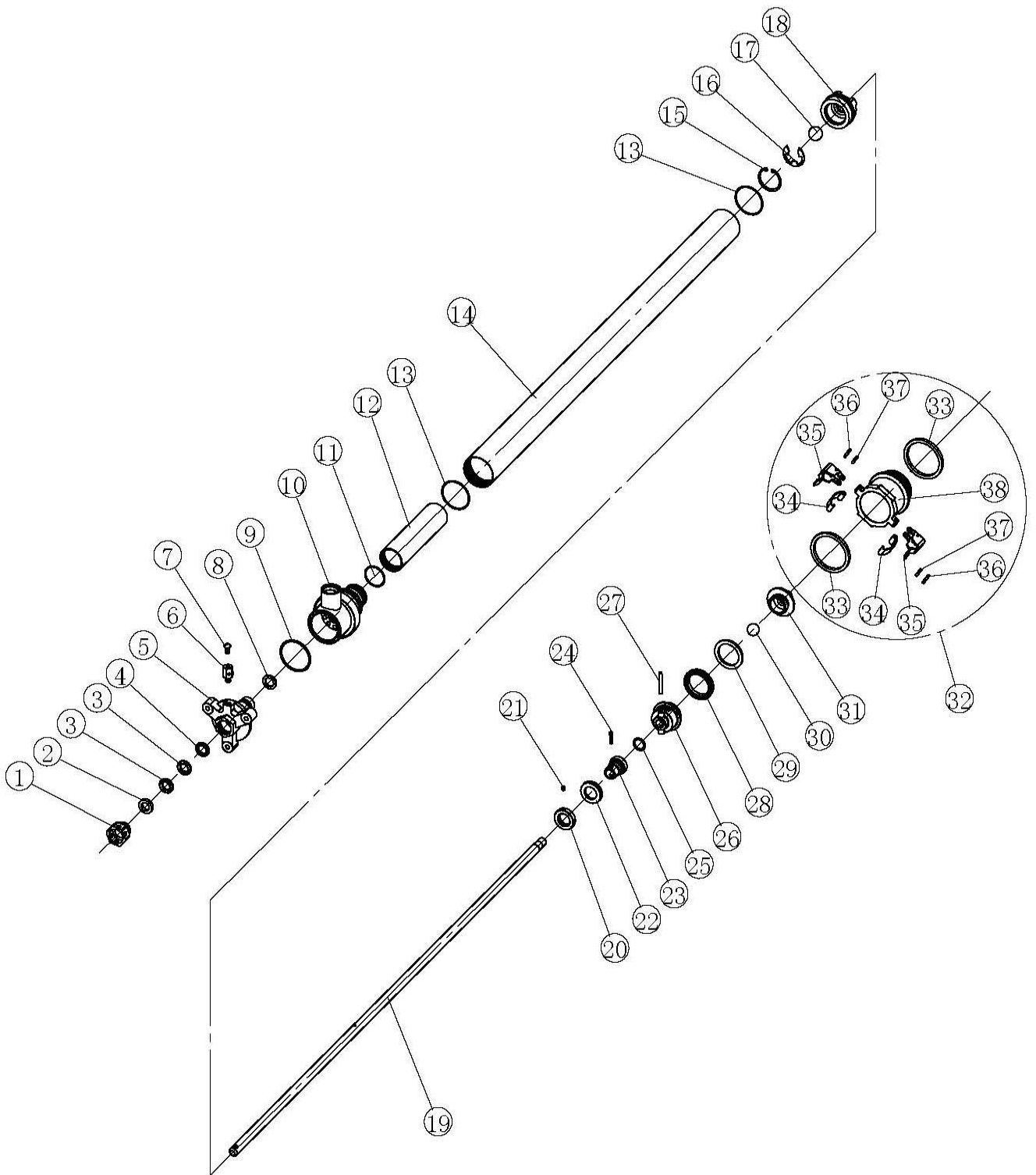

Fluid Section (Model OP350)

ITEM	PART NUMBER	DESCRIPTION	QUANTITY
1	501641	Packing Nut	1
2 *	500033	Seal Retainer	1
3 *	500034	V- Packing	2
4 *	500035	Seal Expander	1
5	500037	Air Cylinder Mtg Flange	1
6	500038	Grounding Lug	1
7	500039	Round Head Screw	1
8 *	500041	Gasket	1
9 *	500042	O-Ring	1
10	501638	Base	1
11 *	501632	O-Ring	1
12	501639	Pump Pressure Cylinder	1
13 *	500066	O-Ring	2
14	501611	Suction Tube	1
15	500193	Snap Ring	1
16	500192	E-Clip	1
17	500269	Ball	1
18	500191	Foot Valve Housing	1
19	501646	Main Shaft	1
20	501604	U-Cup Retaining Collar	1
21	500062	Soft Point Set Screw	1
22 *	501643	Piston Cup Packing	1
23	500059	Upper Matl Piston-Bottom	1
24	500055	Roll Pin	1
25 *	500056	O-Ring	1
26	500057	Material Piston Housing	1
27	500054	Roll Pin	1
28 *	500063	U-Cup	1
29 *	500064	Wear Ring	1
30	500068	Ball	1
31	500065	Piston Valve Housing	1
32	700008	Bung Adapter Assembly (include 33-38)	1
33 *	500053	Gasket	2
34	500050	Latch Spring	2
35	500049	Clamp Lever	2
36	500051	Roll Pin	2
37	500052	Roll Pin	2
38	500048	Bung Adapter	1

* Included in the Repair Kits (part no. 601045).

5.0 TROUBLESHOOTING

Problem	Causes	Recommended Solutions
Pump does not operate.	Air supply or pressure is inadequate. Air lines restricted.	Increase air pressure. Check for any restrictions in air line.
	Dispensing valve is not open or clogged.	Open and/or clear foot valve.
	Clogged fluid lines, valves, hoses or damaged air motor.	Follow pressure relief procedure to clear obstruction. Service air motor. Replace parts as necessary.
	Depleted or exhausted fluid supply.	Refill fluid. Prime system or flush it.
	Worn or damaged air motor gasket, packing, seal, etc	Service air motor. Replace parts as necessary.
Non-stop air exhaust.	Intake valve or packing worn off.	Replace worn parts
Erratic pump operation.	Intake valve is not completely closed.	Clear obstruction and service pump. Replace parts as necessary.
	Held open or worn intake valve.	Clear obstruction and service pump. Replace parts as necessary.
Low output on upstroke.	Held open or worn piston valve.	Clear obstruction and service pump. Replace parts as necessary.
Low output on down stroke.	Restriction in air lines or air pressure low.	Increase air pressure or supply.
Low output on both strokes.	Closed or clogged valves.	Open valve or clear valve.
	Fluid supply is insufficient or exhausted.	Refill fluid. Prime system or flush it.
	Obstructions in fluid lines, hoses, valves, etc.	Follow pressure relief procedure, then clear obstruction.

6.0 TECHNICAL SPECIFICATIONS

Fluid Ratio.....	2.25:1
Maximum Output Flow (continuous).....	5.0 gpm(18.9 lpm)
Maximum Output Flow (intermittent).....	7.5 gpm(28.4 lpm)
Maximum Output Pressure.....	405 psi (28 bar)
Maximum Air Input Pressure.....	180 psi (12.4 bar)
Air Inlet Port.....	1/4" npt (f)
Fluid Outlet Port.....	3/4" npt (f)
Fluid Inlet Port (Model OP300S).....	3/4" npt (f)
Rod & Piston Packings.....	Teflon,UHMWPE
Rod & Cylinder.....	Stainless Steel
Weight (OP300S).....	19 lb (8.6 kg)
Weight (OP350).....	24 lb (10.9 kg)
Dimensions :	

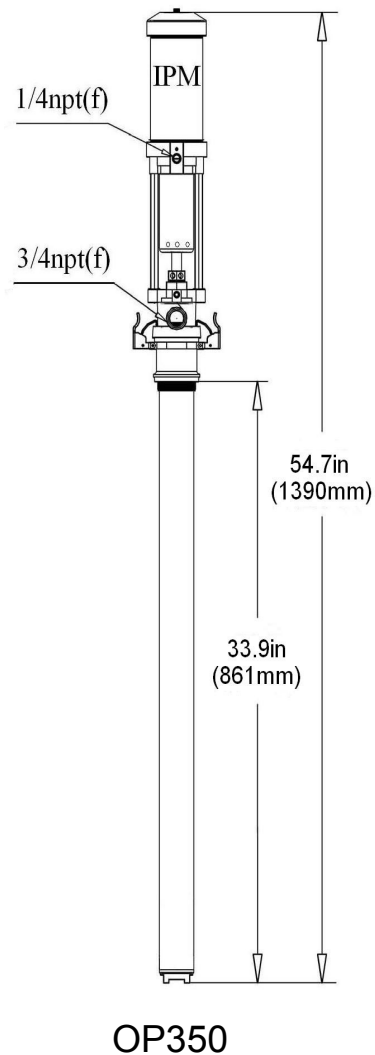
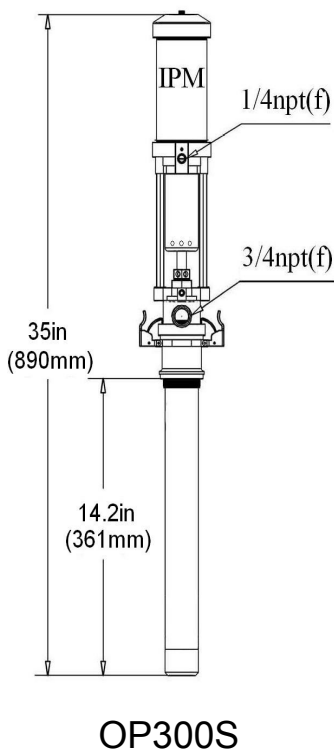

7.0 PERFORMANCE

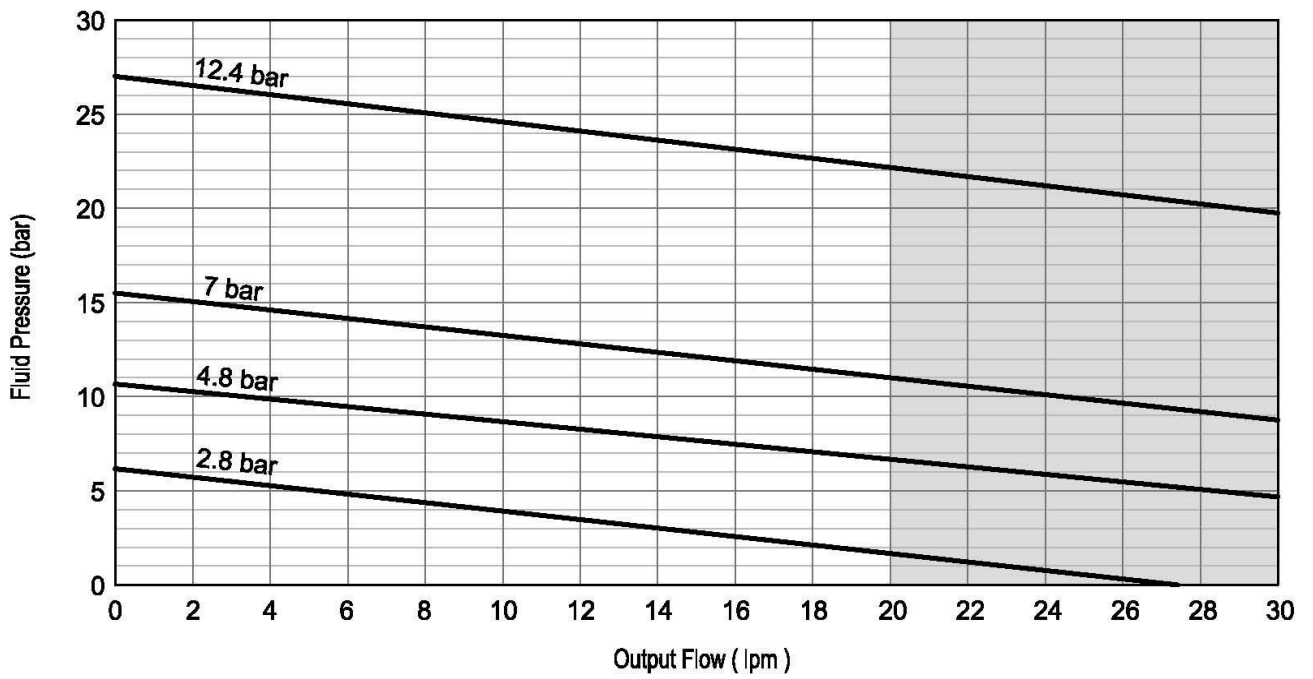
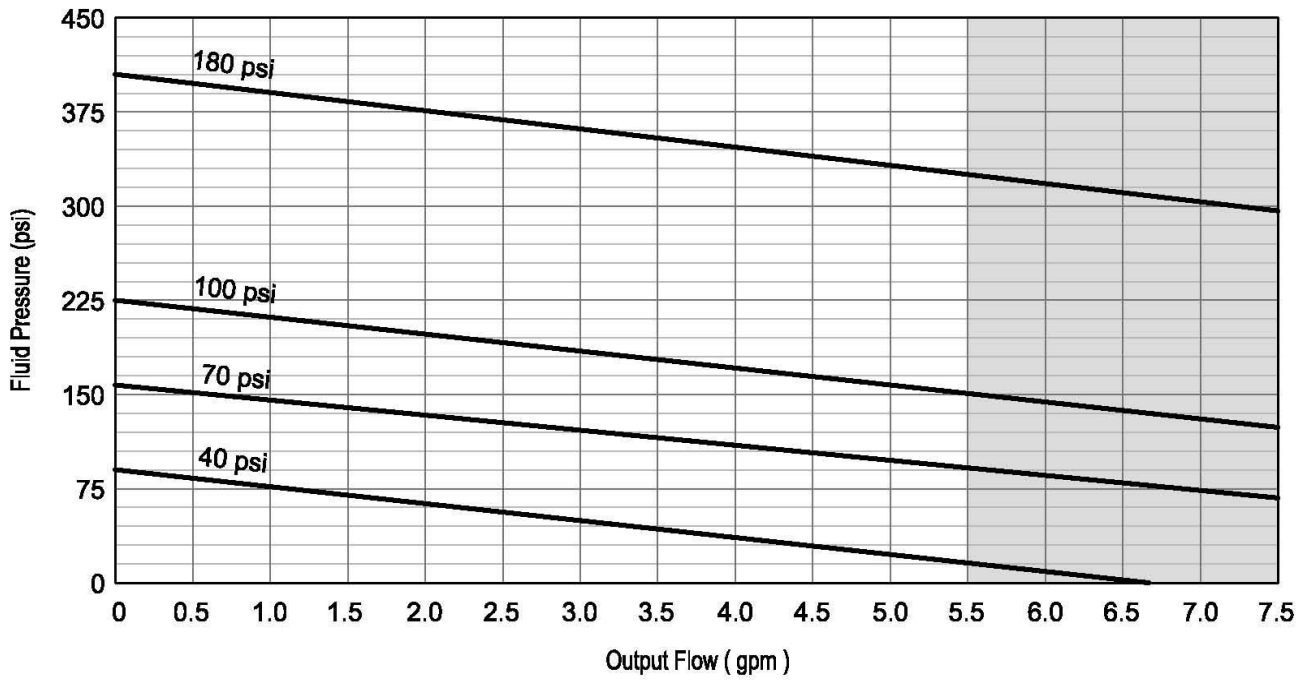

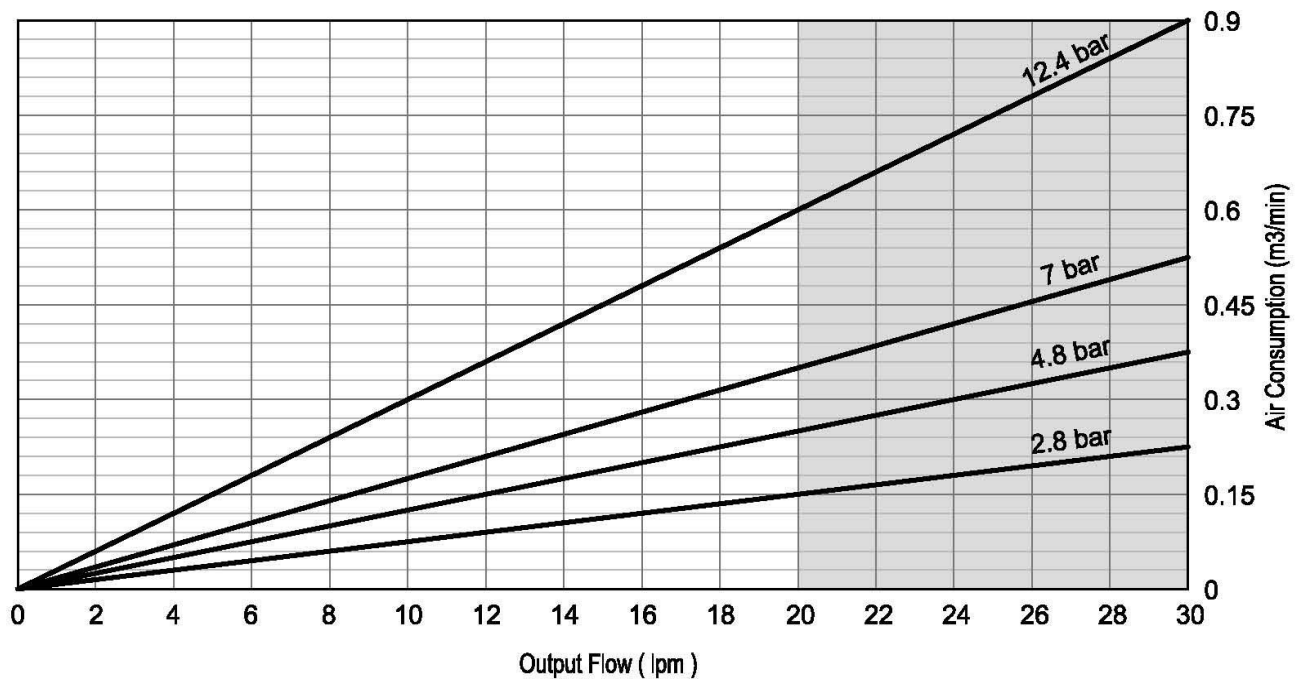
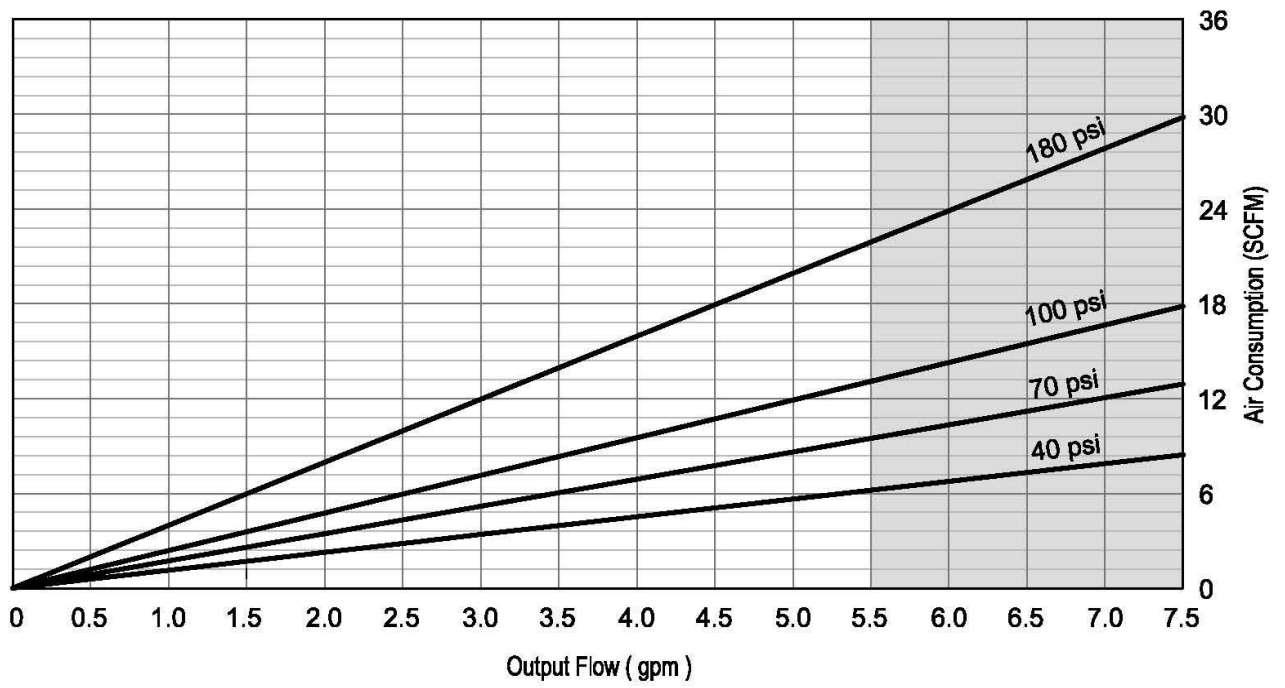

8.0 WARRANTY AND DISCLAIMER

WARRANTY

International Pump Manufacturing, Inc. (hereafter designated **IPM**) warrants the equipment it manufactures to be free of defects in materials and workmanship for a period of one (1) year from the date of sale from **IPM** to an authorized IPM distributor or to the original end user and/or purchaser. **IPM** will, at its discretion, repair or replace any part of the equipment proven to be defective. This warranty applies only when the equipment is used for the intended purpose and has been installed, operated and maintained in accordance with written operating procedures.

A condition of the warranty is the prepaid return of the equipment to an authorized distributor of **IPM** who shall provide verification of the warranty claim. **IPM** will repair or replace free of charge any parts found and verified to be defective or damaged upon receipt of equipment. Shipping will be prepaid for the repaired or replaced parts under warranty. Should inspection of the equipment reveal no defects in material or workmanship repairs will be made at the standard IPM rate, which will include parts, inspection, labor, packaging and shipping.

The warranty does not apply nor shall **IPM** be liable for damage, operational wear, malfunction of equipment caused by improper installation, misuse, chemical abrasion or corrosion, operator negligence, accident, tampering or altering of equipment, lack of improper maintenance and/or by substitution of non-**IPM** parts. Additionally, **IPM** shall not be liable for nor does the warranty apply to operational wear, damage or malfunction caused by incompatibility of accessories, components, structures, equipment or materials not supplied by **IPM**. The warranty does not apply to nor will IPM be responsible for the improper operation, maintenance, design, manufacture, installation of components, accessories, equipment or structures not supplied by **IPM**.

The warranty is void unless the Warranty Registration Card is properly completed and returned to **IPM** within ONE (1) month of the date of the sale.

LIMITATIONS AND DISCLAIMERS

This warranty is the sole and exclusive remedy for the purchaser. No other warranties, expressed or implied, warranties for fitness of purpose or merchantability, or non-contractual liabilities are made by **IPM**, including product liability, whether on negligence or a strict liability basis. Liability for directly special or non-contractual damages or loss is expressly excluded and denied. **IPM's** liability shall in no case exceed the amount of the purchase price.

IPM does not warrant and disclaims implied warranties of merchantability and fitness for a particular purpose, components, accessories, equipment, materials sold but not manufactured by **IPM**. These parts (valves, hoses, fittings, etc.) are subject to the provisions within the warranty of the actual manufacturer of these items. **IPM** will provide reasonable assistance with warranty claims on these items.



**3107 142nd Avenue East Suite 106
Sumner, WA 98390
U.S.A.**

**TEL: (253) 863 2222 FAX: (253) 863 2223
Website: www.ipmpumps.com**

Updated June 2014